

**FSW21801**

## Square Pull Up Station Pro

**KOMPAN**<sup>®</sup>  
Let's play



The Square Pull Up Station can be used in many ways and by multiple users at the same time. This Pro-version has 150 cm wide pull up bars with plenty of space to do typewriter pull ups and dynamic exercises. The dimension of the pull up bar is optimized to 32 mm for improved grip.

Exercises range from normal pull ups to the most dynamic and advanced exercises such as the Flying Monkey, where you fly from one bar to another. These are just two out of the more than 20 exercises that can be found in the KOMPAN Sport & Fitness app.

<b>Grupa</b>	Siłownie zewnętrzne - plenerowe
<b>Kategoria</b>	Street Workout & Kalistenika
<b>Optymalny wiek użytkownika</b>	13 - 16+
<b>Maksymalna wysokość upadku</b>	133
<b>Wysokość (cm)</b>	240
<b>Stefa bezpieczeństwa</b>	19.4 m2



**SUR-  
FACE**

**IN-  
GROU.**

**ASTM**



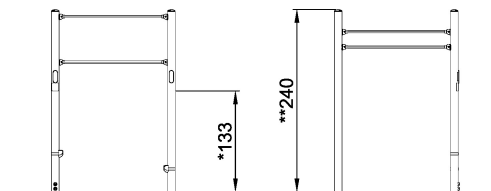
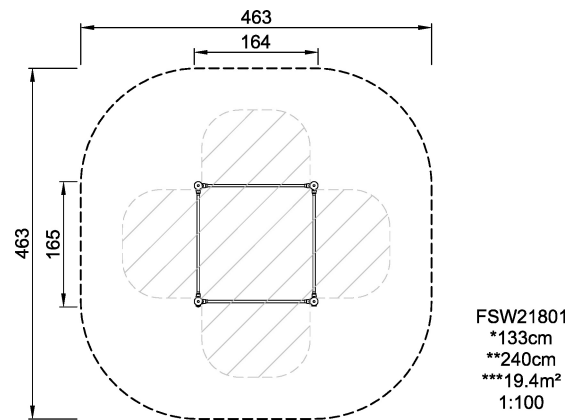

\* = Najwyższy punkt powierzchni użytkowej.  
\*\* = Wysokość produktu.

<b>Waga najcięższego produktu</b>	kg.	<b>Liczba osób potrzebnych do montażu</b>	Ludzie
<b>Ilość betonu</b>	NaN m <sup>3</sup>	<b>Czas montażu</b>	Godziny otwarcia
<b>Liczba fundamentów</b>	NaN	<b>Głębokość wykopu</b>	NaN m <sup>3</sup>