

**FSW21800**

## Square Pull Up Station

**KOMPAN**<sup>®</sup>  
Let's play



The Square Pull Up Station can be used in many ways and by multiple users at the same time. Exercises range from normal pull ups to the most dynamic and advanced exercises such as the Flying Monkey, where you fly from one bar to another. These are just two out of the more than 20 exercises that can be found in the KOMPAN Sport & Fitness app.

<b>Grupa</b>	Sport & Fitness
<b>Kategoria</b>	Tory przeszkód
<b>Optymalny wiek użytkownika</b>	13 - 16+
<b>Maksymalna wysokość upadku</b>	133
<b>Wysokość (cm)</b>	240
<b>Stefa bezpieczeństwa</b>	18.5 m <sup>2</sup>



TRAINING



SUR-  
FACE

IN-  
GROU.

ASTM



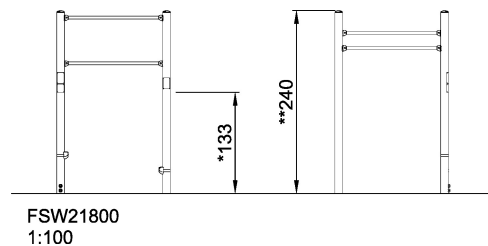
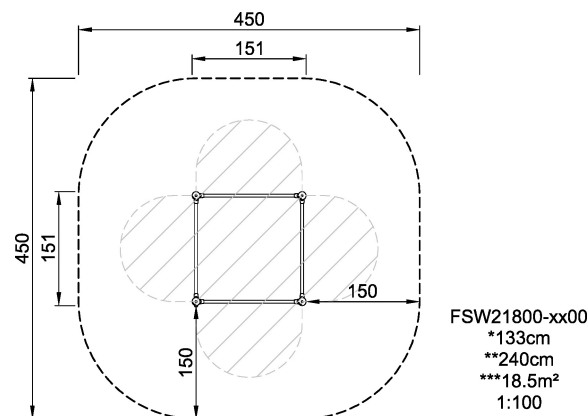

\* = Najwyższy punkt powierzchni użytkowej.  
\*\* = Wysokość produktu.

<b>Waga najcięższego produktu</b>	kg.	<b>Liczba osób potrzebnych do montażu</b>	1 Ludzie
<b>Ilość betonu</b>	NaN m <sup>3</sup>	<b>Czas montażu</b>	2 Godziny otwarcia
<b>Liczba fundamentów</b>	NaN	<b>Głębokość wykopu</b>	NaN m <sup>3</sup>