

FSW21001

Triple Parallel Bars High

KOMPAN
Let's play

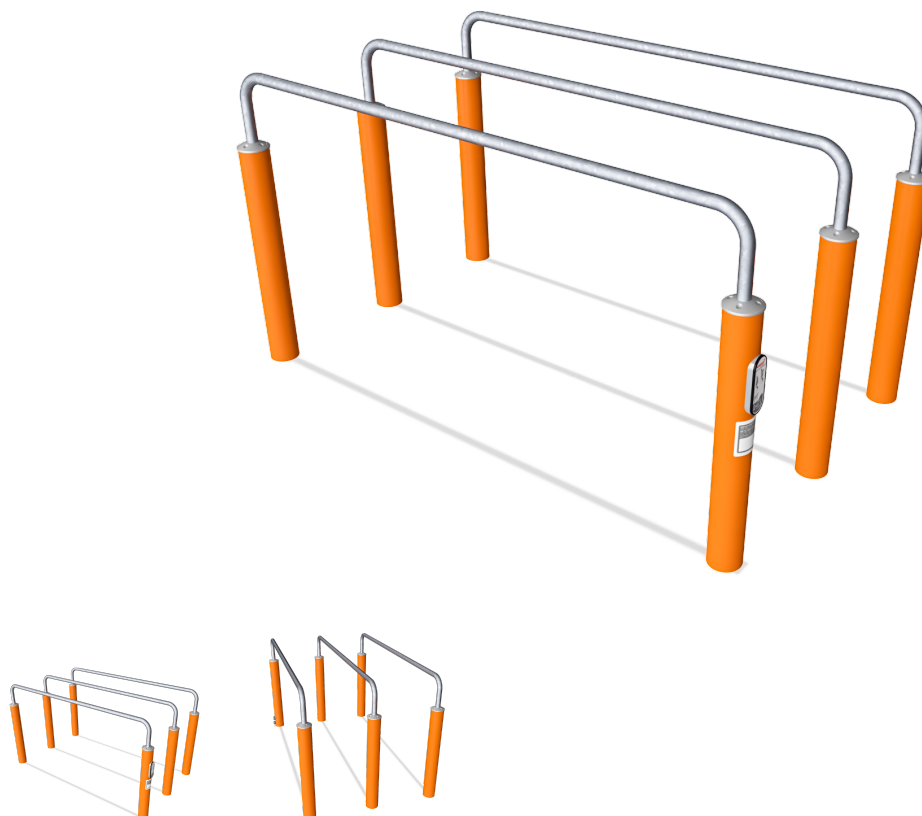

A set of three bars at equal height, 115 cm, ideal for hand balancing exercises as known from the classic gym, and excellent for the core and overall strength. Parallel bars are perfect for doing dips, which is great for strengthening the chest, shoulder and arm muscles.

Grupa

Siłownie zewnętrzne - plenerowe

Kategoria

Street Workout & Kalistenika

Optymalny wiek użytkownika

13 - 16+

Wysokość (cm)

115

Stefa bezpieczeństwa

18.5 m²



**SUR-
FACE**

**IN-
GROU.**

ASTM



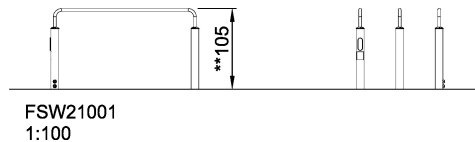
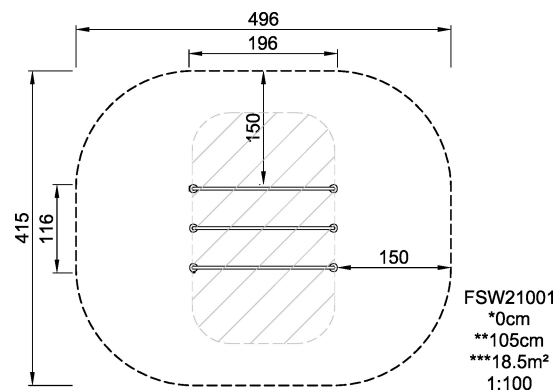

* = Najwyższy punkt powierzchni użytkowej.
** = Wysokość produktu.

| | | | |
|-----------------------------------|--------------------|---|--------------------|
| Waga najcięższego produktu | kg. | Liczba osób potrzebnych do montażu | Ludzie |
| Ilość betonu | NaN m ³ | Czas montażu | Godziny otwarcia |
| Liczba fundamentów | NaN | Głębokość wykopu | NaN m ³ |