

FSW20700 Multi Net

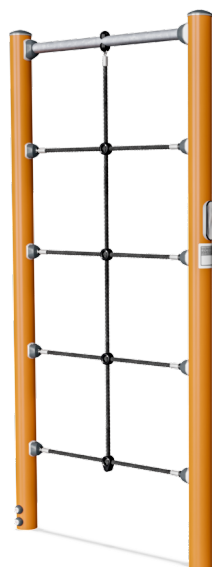

A climbing structure with an overhead pull up bar that offers support for varying the difficulty levels of own bodyweight exercises. The Multi Net is perfect as a training tool preparing for climbing movements in obstacle and survival runs.

| | |
|-----------------------------------|---------------------------------|
| Grupa | Siłownie zewnętrzne - plenerowe |
| Kategoria | Street Workout & Kalistenika |
| Optymalny wiek użytkownika | 13 - 16+ |
| Maksymalna wysokość upadku | 233 |
| Wysokość (cm) | 240 |
| Stefa bezpieczeństwa | 18.5 m2 |



TRAINING



SUR-
FACE

IN-
GROU.

ASTM



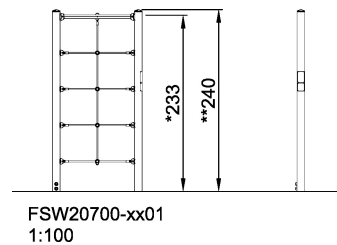
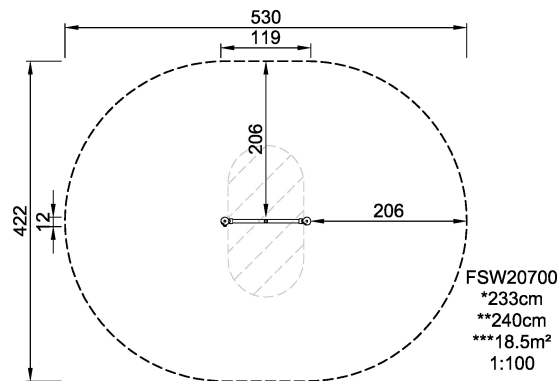

* = Najwyższy punkt powierzchni użytkowej.
** = Wysokość produktu.

| | | | |
|-----------------------------------|--------------------|---|--------------------|
| Waga najcięższego produktu | kg. | Liczba osób potrzebnych do montażu | 1 Ludzie |
| Ilość betonu | NaN m ³ | Czas montażu | 2 Godziny otwarcia |
| Liczba fundamentów | NaN | Głębokość wykopu | NaN m ³ |