

FSW20400 Decline Bench

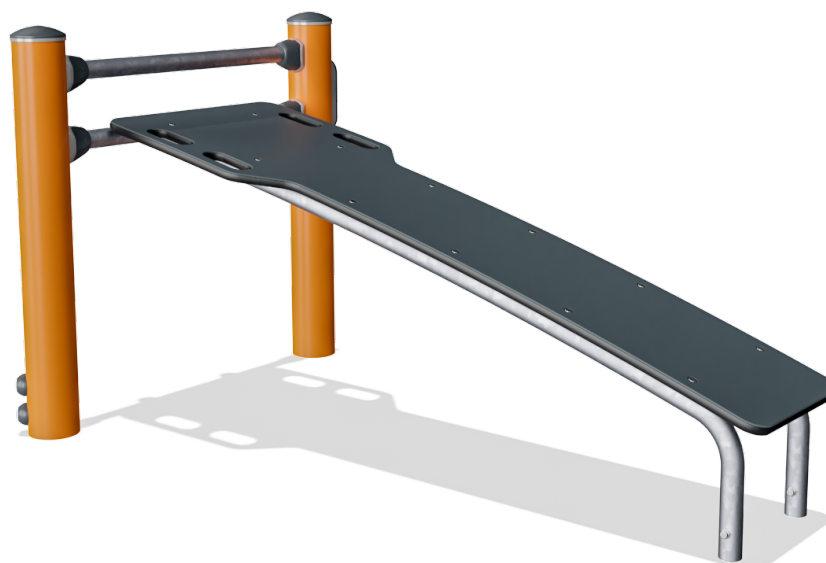

The incline bench, similar to the straight bench, is perfect for training the core with lower back and ab exercises such as leg lifts and sit ups. The durable Ekogrip® surfacing offers perfect grip, allowing the bench to be used as a jump box for performing various step and jump exercises under all weather conditions. The bench has a 15 degree incline, increasing the difficulty level of the exercises, making you work out harder.

Grupa	Siłownie zewnętrzne - plenerowe
Kategoria	Cross Training
Optymalny wiek użytkownika	13 - 16+
Maksymalna wysokość upadku⁶³	
Wysokość (cm)	81
Stefa bezpieczeństwa	14 m ²



TRAINING



SUR-
FACE

IN-
GROU.

ASTM



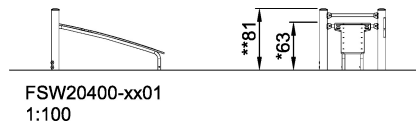
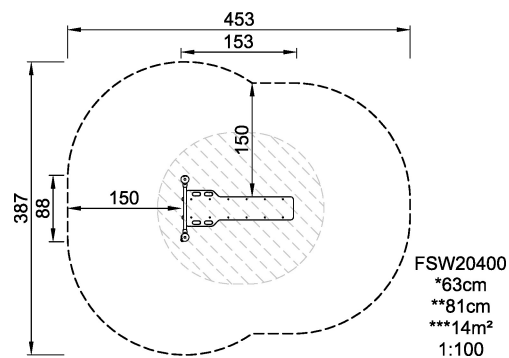

* = Najwyższy punkt powierzchni użytkowej.
** = Wysokość produktu.

Waga najcięższego produktu	kg.	Liczba osób potrzebnych do montażu	1 Ludzie
Ilość betonu	NaN m ³	Czas montażu	2 Godziny otwarcia
Liczba fundamentów	NaN	Głębokość wykopu	NaN m ³