

# FSW20300 Bench

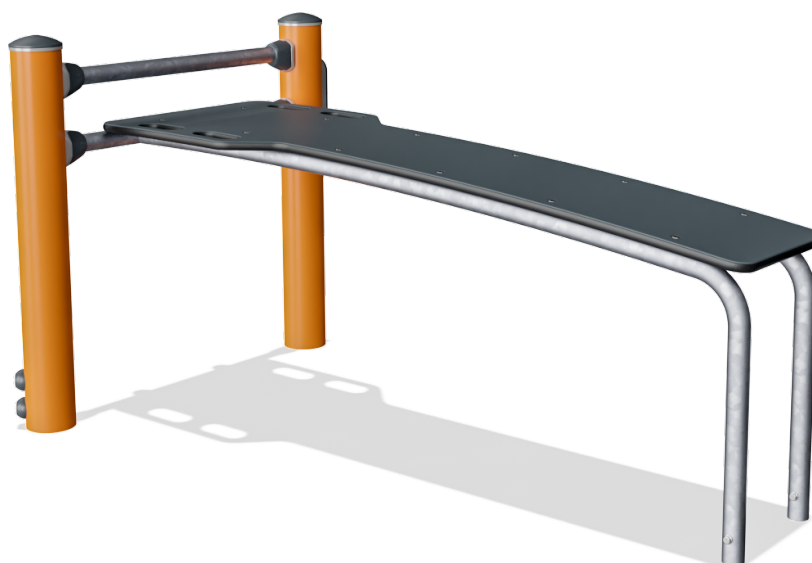

The Straight Bench is perfect for training the core with lower back and ab exercises such as leg lifts and sit ups. The durable Ekogrip® surfacing offers perfect grip, allowing the bench to be used as a jump box for performing various step and jump exercises under all weather conditions.

<b>Grupa</b>	Siłownie zewnętrzne - plenerowe
<b>Kategoria</b>	Cross Training
<b>Optimalny wiek użytkownika</b>	13 - 16+
<b>Maksymalna wysokość upadku</b>	63
<b>Wysokość (cm)</b>	81
<b>Stefa bezpieczeństwa</b>	14 m <sup>2</sup>



TRAINING



SUR-  
FACE

IN-  
GROU.

ASTM



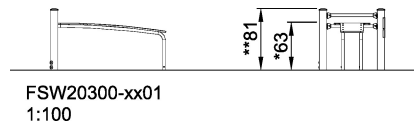
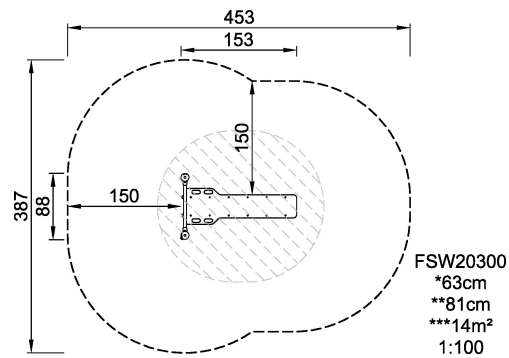

\* = Najwyższy punkt powierzchni użytkowej.  
\*\* = Wysokość produktu.

<b>Waga najcięższego produktu</b>	kg.	<b>Liczba osób potrzebnych do montażu</b>	1 Ludzie
<b>Ilość betonu</b>	NaN m <sup>3</sup>	<b>Czas montażu</b>	2 Godziny otwarcia
<b>Liczba fundamentów</b>	NaN	<b>Głębokość wykopu</b>	NaN m <sup>3</sup>