

# FSW10101 Combi 1 Pro

**KOMPAN**  
Let's play

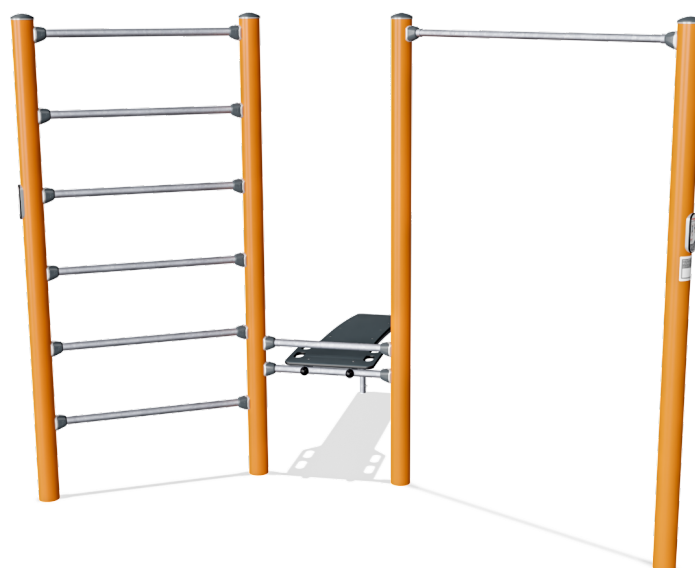

Space efficient combination of essential calisthenics and street workout equipment with a pull up bar, bench and Swedish ladder.

A trainer's favourite, because it is the perfect training station for using additional exercise tools, such as suspension trainers and small weights.

This Pro-version has an 150 cm wide pull up bar with plenty of space to do typewriter pull ups and dynamic exercises. The dimension of the pull up bar is optimized to 32 mm for improved grip.

<b>Grupa</b>	Siłownie zewnętrzne - plenerowe
<b>Kategoria</b>	Street Workout & Kalistenika
<b>Optymalny wiek użytkownika</b>	13 - 16+
<b>Maksymalna wysokość upadku</b>	233
<b>Wysokość (cm)</b>	240
<b>Stefa bezpieczeństwa</b>	26.2 m2



**SUR-  
FACE**

**IN-  
GROU.**

**ASTM**



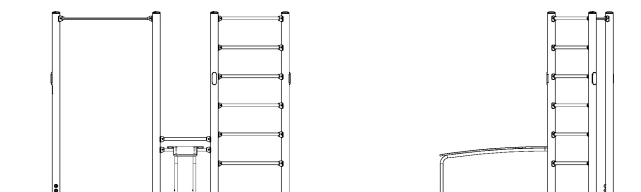
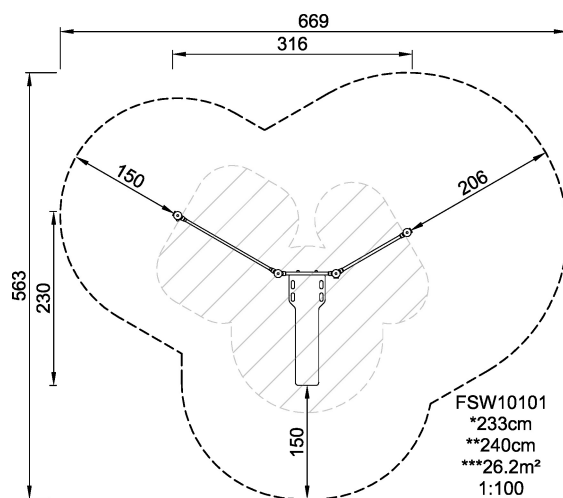

FSW10101  
1:100

\* = Najwyższy punkt powierzchni użytkowej.  
\*\* = Wysokość produktu.

<b>Waga najcięższego produktu</b>	kg.	<b>Liczba osób potrzebnych do montażu</b>	Ludzie
<b>Ilość betonu</b>	NaN m3	<b>Czas montażu</b>	Godziny otwarcia
<b>Liczba fundamentów</b>	NaN	<b>Głębokość wykopu</b>	NaN m3