

FST224 Wobble + Step

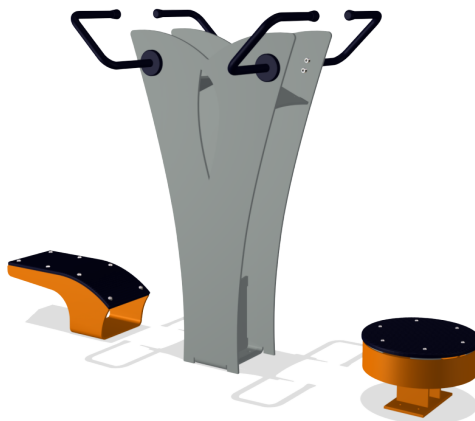

A dual device with on one side the Helix, and on the other the Step. The Helix is an unsteady surface for balance exercises, excellent for improving the muscles in the ankle, knee and torso. The Step is probably the simplest and most versatile device in the Standing-Strong range; so many practical exercises can be done with a step.

Grupa

Siłownie zewnętrzne
- plenerowe

Kategoria

Circuit Training

Optymalny wiek użytkownika 13 - 16+

Maksymalna wysokość upadku 29

Wysokość (cm)

147

Stefa bezpieczeństwa

14.3 m²



TRAINING



SUR-
FACE

IN-
GROU.

ASTM



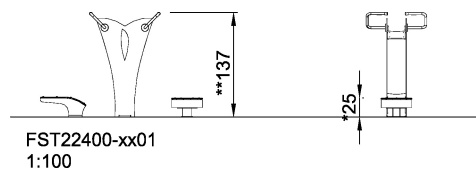
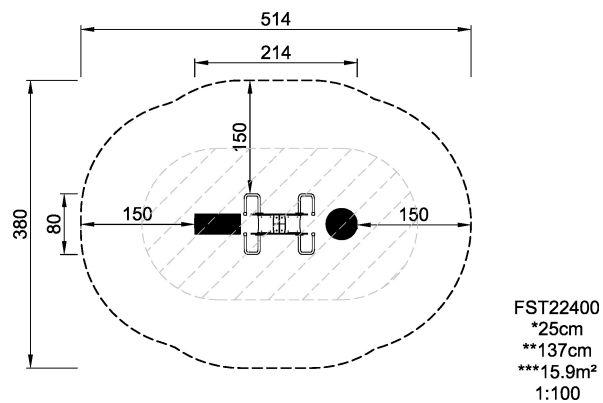

* = Najwyższy punkt powierzchni użytkowej.
** = Wysokość produktu.

Waga najcięższego produktu	kg.	Liczba osób potrzebnych do montażu	1 Ludzie
Ilość betonu	NaN m ³	Czas montażu	2 Godziny otwarcia
Liczba fundamentów	NaN	Głębokość wykopu	NaN m ³